

Exalto wiper cover

For wiper type: 223 BD / 223 BDS



Cat. no. 2101 (white cover) • 2115 (black cover)

Exalto
Quality Marine Equipment

USER MANUAL

General information

The 223BD motor cover kit consists of a two piece cover (base plate and motor cover) and all the necessary parts to install the cover, including: wiring glands, plastic rivets and sealing plates. It can be installed as it is or painted to match a color scheme.

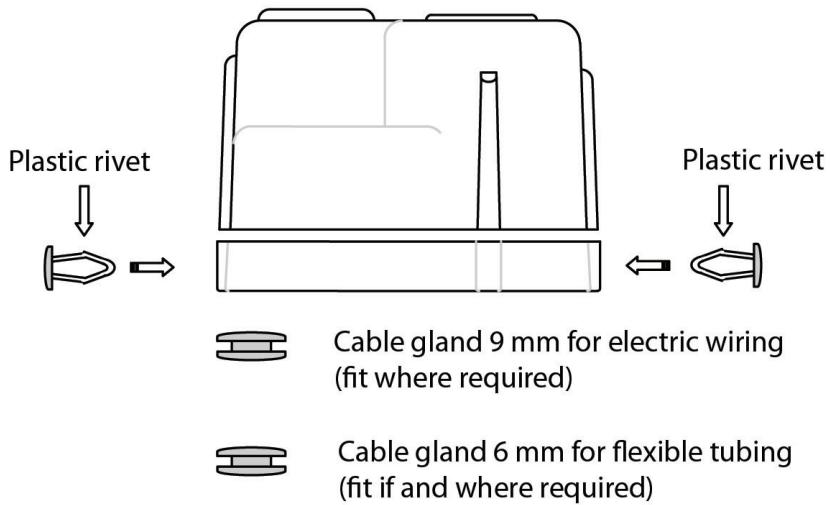

A complete cover kit consists of:

Qty.	Description	Cat. no. White	Cat. no. Black
1	Main cover	2101	2115
1	Base plate	2101	2115
2	Sealing plates	2198.49	2198.44
3	Plastic rivets (to secure cover)	2198.48	2198.58
1	Cable gland (6 mm flexible tubing)	2198.47	2198.47
1	Cable gland (9 mm for wiring)	2198.46	2198.46
1	Installation instructions		

Fitting instructions

- Place one sealing plate on the motor side of the base plate.
- Insert the wiper into the sealing gasket and base plate.
- Apply the second sealing plate to the outside of the base plate. The motor, base plate and gaskets need to make a watertight seal.
- Install the wiper and base plate assembly to the bulkhead by following the standard installation instructions provided in your wiper motor manual.
- Before fitting the main cover, determine the location of the two cable glands; one for the electric cable and one for the washing system (if used).
- Drill a 12 mm ($\frac{1}{2}$ ") hole for the cable gland for the electric cable and push the gland into place.
- Feed the electric cable through the gland.
- Drill a 9 mm ($\frac{3}{8}$ ") hole for the gland for the flexible tubing (only in case a washing jet is fitted) and push the gland into place.
- Feed the flexible tubing through the cable gland and slide the main cover into place.
- Secure the main cover to the base plate by pressing the three plastic rivets into their respective holes. The sealing gaskets are made of soft rubber and some pressure may be required to make the holes matching.

Note

A 100% water tightness of the cover cannot be guaranteed. It is advised that a small hole be drilled in the lowest point of the cover (determined after installation), allowing any water that may have entered the cover to drain out.

April 2009

Exalto B.V.

- P.O. Box 40
3370 AA Hardinxveld-Giessendam
The Netherlands
- **T** +31 (0)184 615 800
- **F** +31 (0)184 618 200
- **E** wipers@exalto.com
- **I** www.exaltowipers.com

© Exalto B.V.